

Rodia®

250RS SERIES

PROFESSIONAL DIAMOND TILE SAWS

259RS • 2512RS • 2515RS

2 HP
3 HP HiPOWER



DIAMOND TILE SAW

OPERATING MANUAL



CAUTION: Carefully read and understand all Safety and Operating Procedures prior to using the Rodia® machine. Keep this Manual in a safe place for future reference



ATTENTION: As our engineers are constantly conducting research and development on our machinery to develop quality products for the marketplace, our product model(s) can be changed without notice.

Enter the Serial Number of your new Rodia® Tile Saw in the box below. The Serial Number is located on the switch box.

CONTENTS

Rodia Safety 3
 Safety Messages 3
 Damage Prevention and 3
 Information Messages 3
 General Safety Precautions and Hazard Symbols 3
 California Proposition 65 Message 6
 Electrical Requirements and Grounding Instructions. 6

Machine Specifications 8
 Cutting Head. 8
 Blade Guard 8
 Saw spindle 8
 Cutting table 9
 Cooling system 9
 Technical Data. 9

Unpacking & Setting Up 9
 Unpacking and Assembly. 9
 Setting the Cutting Depth 10
 Cooling System 10
 Connecting to Power Supply 10
 Motor Protection 10
 Replacing the Cutting Blade 10

Operating Instructions. 11
 Single Step Cutting 11
 Multiple Step Cutting. 11
 45° Miter Cutting 11

Maintenance & Troubleshooting 12
 General Maintenance. 12
 Diamond Blade Dressing 12
 Troubleshooting 13
 Spare Parts 14

Optional Accessories 15
 Side Table. 15
 Dressing Stone. 15
 Legs with Wheels 15
 GFCI Switch 15

RODIA SAFETY



It is extremely important that you read and understand all of the safety instructions, the operating instructions and the maintenance instructions. If these instructions are not followed, serious injuries and/or death could occur to you or to others. Also, failure to read and follow the enclosed maintenance instructions can lead to equipment failure, damage to the equipment or reduced lifetime of the equipment.

Safety Messages

Safety messages are used to inform the person(s) using this equipment of the potential hazards that could lead to equipment damage, serious injury or even death. The safety messages within this manual will be followed by one of the following (3) three words that identify the severity of the damage.



DANGER: *It is important that all instructions within this manual be followed. If the instructions are not followed it is possible that serious injuries could occur as well as death.*



WARNING: *It is important that all instructions within this manual be followed. If the instructions are not followed it is possible that serious injuries could occur as well as death.*



CAUTION: *It is important that all instructions within this manual be followed. If the instructions are not followed it is possible that serious injuries could occur as well as death.*

Damage Prevention and Information Messages

A Damage Prevention Message is to inform the user of important information and/or instructions that could lead to equipment or other property damage if not followed. Information Messages convey information that pertains to the equipment being used.

Each message will be preceded by the word NOTE, as in the example below.

NOTE:

Equipment and/or property damage may result if these instructions are not followed.

General Safety Precautions and Hazard Symbols

In order to prevent injury, the following safety precautions and symbols should be followed at all times!

Safety Precautions:

- **MACHINE GUARDS SHOULD BE IN PLACE AT ALL TIMES**
It is important that all machine guards remain in place and in proper working condition. This is to prevent serious injury, death or damage to the equipment.
- **REMOVE ADJUSTING TOOLS**
The machine is supplied with some adjusting tools for equipment maintenance. It is important that the user of the machine makes sure that all tools are removed or in their proper storage area before the machine is turned on.
- **KEEPING THE WORK AREA CLEAN**
It is important that the working area be clean so as to avoid potential accidents or injuries.
- **DO NOT USE THE EQUIPMENT IN DANGEROUS ENVIRONMENTS**
It is important that power tools not be used in wet environments. The equipment should never be used in the rain. Also, it is advisable to keep the work-

ing area well lit.

- **CHILDREN SHOULD BE KEPT AWAY FROM THE WORKING AREA**

Only the operator of the equipment should be in the working area. All other people especially children should be kept away at a safe distance.

- **KEEP THE WORKING AREA CHILDPROOF**

It is important to keep the working area child proof. This can be done by using locks on the equipment, plastic plugs for the electrical outlets and possibly even master switches on the equipment.

- **DO NOT DRY CUT WITH THE MACHINE**

The machine is not intended for dry cutting use. Always use sufficient water to wet cut tile, brick or natural stone. Dry cutting will result in dangerous dust levels (See also California Proposition 65 message) and will damage the installed water pump. any equipment that is returned with a damaged water pump due to dry cutting will be repaired or replaced totally at the customers expence. There will be no warranty claim.

- **FORCING THE TOOL**

The equipment was designed to do a certain job. Do not force the equipment to do something that it wasn't designed to do.

- **USING THE PROPER EXTENSION CORD**

If you plan to use an extension cord make sure it is in proper (good) working condition. Be sure that the extension cord is heavy enough to carry the current that the machine requires to run properly. If you use an extension cord that is underpowered a drop in voltage may occur along with a loss of power and/or overheating of the equipment

- **CLOTHING**

It is important that the operator does

not wear loose clothing that can potentially get caught in moving parts of the equipment. It is recommended to wear non-slip shoes along with a hair covering to keep hair away from the moving parts.

- **SAFETY GLASSES AND HEARING PROTECTION**

It is important to wear safety glasses and hearing protection when operating any type of equipment. Be sure that the safety glasses you wear are impact resistant.

- **SECURE WORK**

Clamps or a vise should be used to hold your work whenever practical. Keeping your hands free to operate the machine is safer. When securing the material to be cut by hand, be sure your hands stay as far away as possible from the rotating saw blade.

- **PROPER FOOTING**

It is important to keep proper footing and balance at all times when operating equipment. If proper footing is not observed by doing such things as overreaching, serious injury may occur.

- **TOOL MAINTENANCE**

It is important to keep tools clean and in good working order. This will result in optimal performance of the machine. Always follow the maintenance instructions for proper tool maintenance.

- **DISCONNECT TOOLS.**

It is important to disconnect the power tool before servicing the equipment. This should be done when changing accessories on the machine, changing blades and for other such things.

- **REDUCING ACCIDENTAL STARTING OF MACHINE**

It is important to be sure that the switch is in the OFF position before you plug the machine into an electrical outlet.

- **EQUIPMENT ACCESSORIES.**

It is important that you refer to the



READ MANUAL CAREFULLY BEFORE USE



WEAR SAFETY GEAR



DO NOT SPRAY WATER ON MOTOR



TURN OFF SAW BEFORE PLUGGING IN



USE GROUND FAULT CIRCUIT INTERRUPTOR



KEEP AWAY FROM MOVING PARTS



DO NOT REMOVE BLADE GUARD

owner's manual for determining what are the recommended accessories to use with this type of equipment. Using accessories that are not recommended in the owner's manual may increase the risk of personal injury and/or to people that are within close proximity of the machinery.

- **CHECKING THE EQUIPMENT FOR DAMAGED PARTS.**

It is important to inspect the power tool before using it to check for damaged parts. Any part of the machinery that is damaged should be checked carefully to determine whether or not it should be used and whether or not it can function properly for its intended use.

It is important to check all the moving parts of the machinery for proper alignment and /or possible binding. All broken or damaged parts should be properly repaired or replaced. If these parts are not repaired or replaced the proper operation of the machine could be negatively affected. Damaged saw blades should be replaced immediately.

- **BLADE ROTATION DIRECTION AND FEED ROTATION.**

Always feed work into a blade in the direction of rotation. The blade should always be installed so that the rotation is in the direction of the arrow imprinted on the side of the blade and the blade guard.

- **NEVER LEAVE A TOOL RUNNING UNATTENDED – TURN POWER OFF**

It is important never to leave a tool running when not in use. Also never leave the tool until the blade has come

to a complete stop. It is important to always turn the power tool OFF when leaving the work area or when a cut is finished.

Hazard Symbols:

- **READ MANUAL CAREFULLY BEFORE USE**



Carefully read and understand this operating manual and the enclosed safety instructions prior to using the machine.

- **WEAR SAFETY GEAR**



Always wear safety glasses and hearing protection when operating the machine

- **DO NOT SPRAY WATER ON MOTOR**



Avoid direct water spray on motor and switch housing when cleaning of or watering down machine.

- **TURN OFF SAW BEFORE PLUGGING IN**



It is important to make sure that the switch is in the OFF position before plugging the machine into an electrical outlet to prevent accidental starting of the machine.

- **ELECTRICAL SHOCK**



It is important to never touch electrical components of the machine while the machine is in operation.

- KEEP AWAY FROM MOVING PARTS



It is important to keep hands, feet, hair and clothing away from all moving parts to prevent injury. It is also important to be sure that covers and guards are always in their proper position. If not, serious injury can occur.

- DO NOT REMOVE BLADE GUARD



It is important that all machine guards remain in place and in proper working condition. This is to prevent serious injury, death or damage to the equipment.



WARNING: *The use of saws and drills generates dust. Excessive airborne particles may cause irritation to eyes, skin and the respiratory tract. To avoid breathing impairment, always use dust controls and protection suitable to the material being sawed or drilled;*

See OSHA (19 CFR Part 1910.1200). Diamond Blades improperly used are dangerous. Comply with American National Standards Institute Safety Code, B7.1 and, Occupational Safety and Health Act covering speed, Safety Guards, Flanges, Mounting Procedures, General Operating Rules, Handling, Storage and General Machine Conditions.

California Proposition 65 Message

Some dust created by power sanding, sawing, grinding and other construction activities contain chemicals known [to the State of California] to cause cancer, birth defects or other reproductive harm. Some examples of these chemicals are:

- Lead, from lead-based paints
- Crystalline silica, from bricks and

cement and other masonry products

- Arsenic and chromium, from chemically treated lumber

For further information, consult the following sources:

<http://www.osha-slc.gov/sltc/sillicarystalline/index.html>
http://www.oehha.org/prop65/out_of_date/6022kLstA.html

Your risk from these exposures varies depending on how often you do this type of work. To reduce your exposure to these chemicals, work in a well-ventilated area, and work with approved safety equipment, such as dust masks that are specially designed to filter out microscopic particles.

Electrical Requirements and Grounding Instructions

In order to prevent potential electrical shock and injury, the following electrical safety precautions and symbols should be followed at all times!



WARNING: *In case of a malfunction or breakdown, grounding provides a path of least resistance for electric current to reduce the risk of electric shock. This tool is equipped with an electric cord having an equipment-grounding conductor and a grounding plug. The plug must be plugged into a matching outlet that is properly installed and grounded in accordance with all local codes and ordinances.*

- Do not modify the plug provided – if it will not fit the outlet; have the proper outlet installed by a qualified electrician.
- Improper connections of the equipment grounding conductor can result in a

risk of electric shock. The equipment-grounding conductor is the insulated conductor that has an outer surface that is green with or without yellow stripes. If repair or replacement of the electric cord or plug is necessary, do not connect the equipment-grounding conductor to a live terminal.

- Check with a qualified electrician or service personnel if the grounding instructions are not completely understood, or if in doubts to whether the tool is properly grounded.
- Use only 3-wire extension cords that have 3-prong grounding plugs and 3-pole receptacles that accept the tool's plug.
- Repair or replace a damaged or worn cord immediately.



WARNING: *This tool is intended for use on a circuit that has a 3 pole outlet.*



WARNING: *To reduce the risk of electrocution, keep all connections dry and off the ground.*

A Ground Fault Circuit Interrupter (GFCI) should be provided on the circuit(s) or outlet(s) to be used for the Saw. Receptacles are available having built-in GFCI protections and may be used for this measure of safety. A GFCI is not supplied with the machine.

When using an extension cord, the GFCI should be installed closest to the power source, followed by the extension cord and lastly, the saw.



CAUTION: *Shock Hazard. For replacement, use only an identical Rodia water pump, item # 6.513.298*



WARNING: *To avoid the possibility of the machines plug or electrical outlet getting wet, position the saw to one side of a wall mounted outlet. This will prevent water from dripping onto the outlet or plug. A "drip loop" should be arranged by the user to properly position the power cord relative to the power source. The "drip loop" is that part of the cord below the level of the outlet, or the connector, if an extension cord is used.*

This method of positioning the cord prevents the travel of water along the power cord and the possibility of the water coming in contact with the receptacle. If the plug or electrical outlet gets wet, DO NOT unplug the cord. Disconnect the fuse or circuit breaker that supplies power to the machine. Then unplug and examine the machine for the presence of water in the outlet.



WARNING: *It is important to use extension cords that are only intended for outdoor use. These extension cords are identified by a marking "Acceptable for use with outdoor appliances; store indoors while not in use".*



WARNING: *It is important to only use extension cords having an electrical rating not less than the rating of the product.*



WARNING: *It is important not to use damaged extension cords. Examine the extension cords before using it and replace it if it is damaged.*



WARNING: It is important to not abuse the extension cord and do not yank on any cord to disconnect it from the outlet.



WARNING: It is important to keep the cord away from heat and sharp edges.



WARNING: It is important to disconnect the extension cord from the outlet before disconnecting the machine from the extension cord.



WARNING: It is important not to use an extension cord that is undersized. Using an undersized extension cord can result in low voltage to the motor thus resulting in a motor burnout or premature failure.

To choose the proper extension cord:

- Locate the length of extension cord needed in the table below
- Once the proper length is found, move down the column to obtain the correct
- AWG size required for that length of extension cord.

Extension Cord Minimum Gage for Length

Volts	Total Length of Cord [ft]			
120V	25	50	100	150
	AWG	AWG	AWG	AWG
	14	12	Not recommended	

Tile Specific Warnings:



WARNING:

- Always wear eye and hearing protection.
- Always disconnect the saw before conducting any type of service on the machine, includ-

ing when changing cutting blades and cleaning.

- Use the machine only with Rodia 10" wet cutting blades.
- Always replace damaged cutting blade before operating.

MACHINE SPECIFICATIONS

This sawing machine is designed and intended for the professional contractor. The machine is equipped with a saw head which moves horizontally along a guiding beam. The material to be cut is positioned on the saw table. The saw must be fed through the material. Through continuous supply of cooling water the cutting quality is improved as well as the wear on the saw blade is minimized. The cooling water also absorbs the saw dust. The quality and construction of this sawing machine meet the highest standards. The design is based on longevity and minimal maintenance.

The stainless steel construction contributes to a stable, rigid and durable sawing machine. The 4 detachable legs are to be installed in the leg sockets at the underside of the water container and fastened with the knobs.

Cutting head

The cutting head is constructed of cast alloy components. The height adjustment is kept in balance with a spring. A knob secures the cutting head at the desired height.

Blade guard

The blade guard is a stainless steel plate cap with a removable blade cover which is fastened by 3 knobs.

Saw spindle

The spindle flange is mounted on the saw

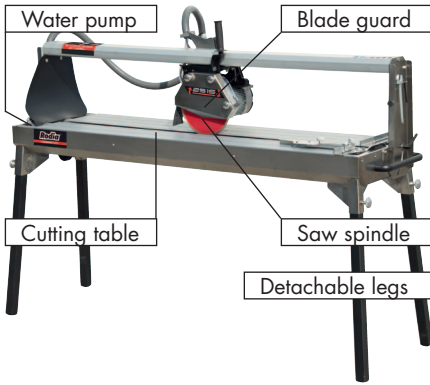

sure most water flows back in the water container.

UNPACKING & SETTING UP

Unpacking and Assembly

- Unpack the tile saw and inspect for any damaged parts.
- Install the legs in the sockets at the under side of the water container and fasten with the knobs. Markings show the right position.
- Level the tile saw by adjusting the legs in the sockets and make sure its stable.
- Release the transportation lock.

spindle. The saw flange is to be mounted on the saw spindle with a hexagon nut to clamp the saw blade.

Cutting table

The cutting table is constructed of removable aluminum components for easy maintenance, and a stainless steel adjustable side stop.

Cooling system

The electrical water pump is switched on simultaneously with the saw motor and supplies cooling water to both sides of the saw blade. A drain hole, with a plug, is located in the water container. Mud flaps prevent most of the water mist and make

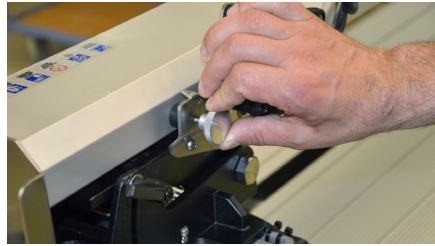

Technical Data

Type	259RS/HP	2512RS/HP	2515RS/HP
Capacity	2 HP/3 HP	2 HP/3 HP	2 HP/3 HP
Blade diameter/hole	10" / 5/8"	10" / 5/8"	10" / 5/8"
Cutting height	max. 2"	max. 2"	max. 2"
Saw spindle speed	3.360 RPM	3.360 RPM	3.360 RPM
Cutting length	34"	48"	59"
Length	48"	61"	73"
Width	19"/20,5"	19"/20,5"	19"/20,5"
Height (without legs)	24"	24"	24"
Weight	115/121 lbs	137/143 lbs	154/161 lbs
Noise level	81 dB (A)	81 dB (A)	81 dB (A)
Noise level (sawing)	92 dB (A)	92 dB (A)	92 dB (A)

Setting the Cutting Depth



CAUTION: By loosening the knob the saw head can be positioned at the desired height.

The saw head is tightened by a spring and may accidentally jump up when the knob is loosened.

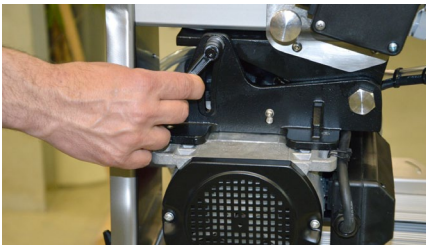

Cooling system



CAUTION: Operating the water pump without a sufficient supply of water may result in pump damage.

- Place the plug in the drain of the water container.
- Fill the container with water until the water pump is completely submerged.

Connecting to power supply



CAUTION: Before connecting the machine make sure that:

- the line voltage corresponds with the data on the machine's specifications plate;
- there is a grounded power supply;
- the extension cord's meets criteria as mentioned in the table on page 8.

Motor protection

The motor is equipped with a thermal safety switch for protection against an overload. When the motor gets overheated, the switch falls back into its initial position and can only be switched on again after the motor has cooled down.

Replacing the cutting blade



WARNING: Make sure to disconnect the machine from the power supply before fitting or replacing the cutting blade or when doing any maintenance on the machine.

- Remove the three knobs of the blade cover.



- Block the sawing spindle with the 6 mm Allen wrench.
- Unscrew the 22 mm hexagon nut with the wrench and remove the saw flange. (Attention: Left-handed screw threading.)
- Clean the saw flanges.
- Fit the new cutting blade on the center ring of the motor flange. (Check the direction of rotation and make sure the blade is well centered.)
- Mount saw flange and tighten with the hexagon nut.

OPERATING INSTRUCTIONS

Single Step Cutting

DO NOT FORCE THE TOOL! It will do the job better and safer at the rate for which it was designed.

Use original Rodia® wet cutting blades only.

- Loosen the Adjustable Cutting Guide retaining knob.

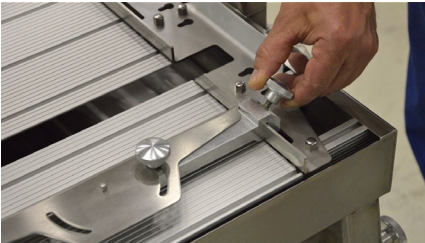

- Position the Adjustable Cutting Guide to desired cutting length.
- Tighten the retaining knob.
- Place the tile against the Ruler/Stop and Cutting Guide.
- Turn the motor ON.
- Verify proper coolant flow on both sides of the blade.
- Perform the cut.
- Turn the motor OFF when work is complete.

Multiple Step Cutting

During this sawing process the saw is positioned at the desired height and moved back and forth through the material to be cut until after a number of steps it is completely cut through.

- Place the material to be cut on the sawing table and position against the fixed stop and eventually the adjustable stop.

- Position the cutting head at the desired height
- Hold the material with one hand while making sure your hand is free from the cutting blade.
- Perform the cut. This process must be repeated until the material has been totally cut through.
- Turn the motor OFF when work is complete.

45° Miter Cutting

The Rodia® Tile Saw is designed to perform 45° Miter Cuts without additional tools.

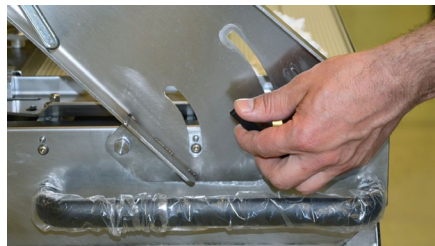

- Loosen the 2 handles on either side of the machine.
- Tilt the cutting head into the 45° position.
- Fasten both handles.
- Place the tile on the cutting table in the desired position.
- Hold the tile down with one hand. (Keep hand away as far as possible from the cutting blade.)
- Turn the motor ON.
- Verify proper coolant flow on both sides of the blade.
- Perform the cut.
- Turn the motor OFF when work is complete.

MAINTENANCE & TROUBLE-SHOOTING

General Maintenance

- The cooling water should be replaced and/or replenished regularly.
- It is recommended to clean the water container, pump, hoses and spray nozzle on a regular basis. For example, place the pump in a bucket of clean water after the sawing job and run the machine for a minute or so. This also guarantees a longer lifetime of the pump.

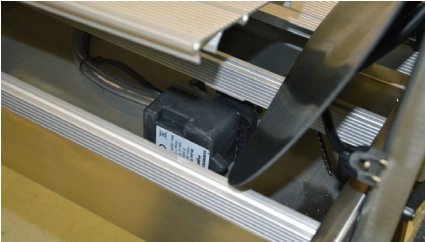

- When the machine is not used for a longer period, the pump should not remain in the muddy cooling water. Cleaning the pump as described above and leaving it outside the water container is recommended.
- Regularly check the saw flanges for wearing out and replace if necessary.

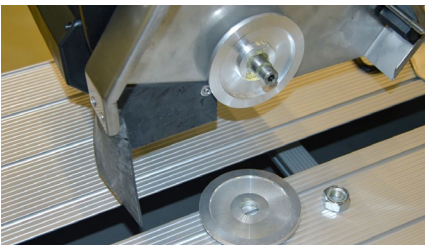

Diamond blade dressing

Diamond blades perform best when they are dressed. After time and use, diamonds on the outer edge of the blade might become glazed or dull.

This will reduce cutting efficiency and possibly cause the blade to bend. As a result the cut will not be straight and misaligned.

When this occurs, the blade needs to be dressed. The diamond blade can be dressed with a Dressing Stick. (Optional Accessory, see page 15.)

Dressing procedure(s):

- Place a Dressing Stick on the saw table.
- Make approx. 10 cuts through the Dressing Stick.

The diamond blade should be sharp again and ready for efficient cutting.

Troubleshooting

<p>The machine does not work.</p>	<ul style="list-style-type: none"> - The power supply cable is damaged or not properly connected. - No voltage in the power outlet. - Start Switch is damaged. 	<ul style="list-style-type: none"> - Press the plug firmly in the power outlet. Check the power supply cable. - Have the power outlet checked. - Have the Switch replaced.
<p>Water does not flow at the blade while the pump is running.</p>	<ul style="list-style-type: none"> - The sprayers are clogged. - The water level in the waterbin is not sufficient. The pump is not totally submerged. - Water valve is closed. 	<ul style="list-style-type: none"> - Clean the sprayers - Fill the waterbin with clean water until the pump is totally submerged. - Open the valve.
<p>Motor is not running properly.</p>	<ul style="list-style-type: none"> - Water may have seeped through inside the motor. - Capacitor is damaged. - Motor bearing are damaged. 	<ul style="list-style-type: none"> - Unplug the power cable and consult your local dealer. - Unplug the power cable and consult your local dealer. - Unplug the power cable and consult your local dealer.
<p>Pump is not running.</p>	<ul style="list-style-type: none"> - The impeller or suction filter of the pump is damaged. - No proper connection of the power cable. 	<ul style="list-style-type: none"> - Replace damaged parts. - Have the connection checked.
<p>Bad cutting alignment.</p>	<ul style="list-style-type: none"> - Machine is not level. - Unlevel working surface. - Improper or glazed diamond blade. 	<ul style="list-style-type: none"> - Loosen the screws for the legs. Pick up the machine a little bit on one end. Let the machine down again and tighten screws. Do the same procedure for the other end. Machine should now be level. - Make sure the machine is placed on a level surface. - Replace or dress the diamond blade.

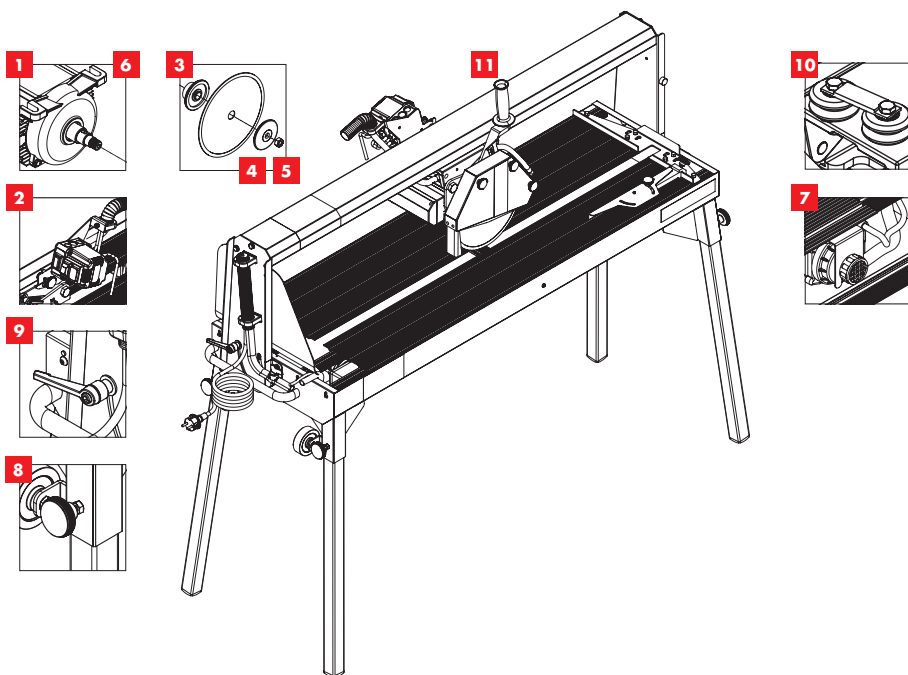
US**RODIA® 250RS SERIES****Spare Parts**

Pos. #	Item Nr. - 2 HP	Item Nr. - 3 HP	Description
01	6.516.007	6.516.049	Motor
02	6.513.022	6.513.221	Switch
03	4.259.035	6.516.061	Motor Flange
04	4.259.007	id.	Saw Flange
05	6.516.006	id.	Flange Nut
06	6.513.021	id.	Capacitor
07	6.513.298	id.	Pump
08	6.509.011	id.	Knob
09	6.509.065	id.	Adjustable Handle
10	4.259.024	id.	Guiding Roller
11	6.509.003	id.	Handle

OPTIONAL ACCESSORIES



Side Table

with squaring arm
Dimensions: 16" x 16"
Qty. 1
Part Nr. 00.25.906



Legs with Wheels

Qty. 2
Part Nr. 00.40.510



GFCI Switch

Qty. 1
Part Nr. 01.10.001

Dressing Stone

Qty. 1
Part Nr. 77.12.001

Rodia[®]

WWW.RODIATOLS.COM

RUSM25085-1505V1